



Twin Groves Energy Storage I & II

McLean County, Illinois

 Installed capacity: **100 MW/400 MWh**

 Estimated commercial operation: **2028**

 Installed capacity will be equivalent to the average consumption of more than **70,300 Illinois homes**.¹

Twin Groves Energy Storage I & II represent an expansion of EDPR NA’s energy infrastructure in McLean County, Illinois. The energy storage sites will be located near the communities of Arrowsmith and Ellsworth, alongside EDPR’s existing Twin Groves Wind I & II. Once online, these projects will share some of the existing electrical infrastructure from Twin Groves Wind I & II. The low-impact batteries will provide additional storage capacity for the utility and system operators by storing electricity from any energy source and delivering it to surrounding communities when needed.

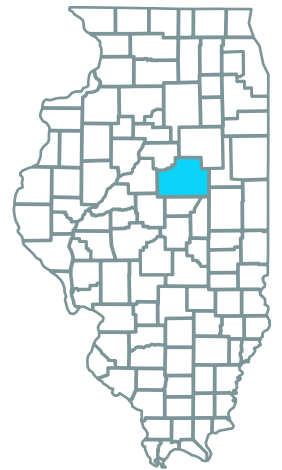

Economic benefits



CAPITAL INVESTMENT
\$170 million



PERMANENT JOBS
2-3 jobs will be created²



\$11 million
WILL BE PAID TO
LOCAL GOVERNMENTS



Millions of dollars
WILL BE SPENT LOCALLY



CONSTRUCTION JOBS
About 50 jobs will be created²

Energy security

Power stored at Twin Groves will support the state of Illinois’s electric grid. The energy storage project will also contribute to the **national energy security for the United States**, helping add on-demand power.

Environment and energy storage

Energy storage facilities are designed to not release pollutants into the air, soil, or waterways. Like batteries used in handheld devices, lithium-ion batteries do not emit electromagnetic fields or contain radioactive materials.

Energy storage safety

Between cell phones, laptops, and power tools, many people have a lithium-ion battery in their pockets or hands at all times. Additionally, energy storage fires are very rare and their rate of frequency is decreasing. Energy storage sites are also highly regulated to ensure safety for neighbors, communities, and technicians.



Twin Groves' environmental impact

The energy storage project will save more than **339 million gallons** of water each year and would prevent the air pollution that causes smog and acid rain.³



How is energy storage useful?



Reduces outages & enhances resilience



Reduces costs and saves money



Builds a stronger, more efficient grid



Supports local economies



How energy storage works

The most common electrochemical storage method is the lithium-ion battery. These are similar to the batteries that power your cell phones, or laptops. Energy storage systems are fuel-neutral. This means that they can capture and dispense electricity from oil, gas, coal, nuclear, geothermal, and EDP Renewables North America's wind and solar energy projects.

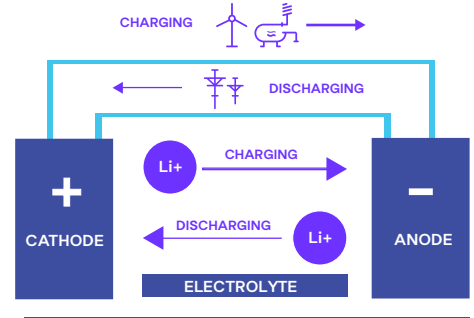

Energy storage enhances reliability, reduces costs, and increases grid resilience.

Grid stability

Energy storage systems allow excess energy, from power plants or the grid, to be stored during off-peak times, and used during times of high demand, including during extreme weather when power generation is limited. Keeping the power on, air-conditioning or heating systems operating, medical systems functioning, and other critical infrastructure working, will help keep people safe and healthy during otherwise vulnerable circumstances.

Scan the QR Code to explore educational resources on renewables and how we are empowering local economies, as well as meeting the energy demand of today.



Scan the QR Code using the camera on your mobile device.

¹The cost and performance of the battery systems are based on an assumption of approximately one cycle per day. Therefore, a 4-hour device has an expected capacity factor of 16.7% (4/24 = 0.167). Household consumption based on 2024 EIA Household Data monthly average consumption by state. This assumes that all energy is stored from a renewable source and discharged at the grid average.

² Full-time equivalent jobs calculated by dividing number of contractor hours worked during construction by 2080.

³Assumes 0.58 gallons of water consumed per kWh of conventional electricity from Lee, Han, & Elgownay, 2016. This assumes that all energy is stored from a renewable source and discharged at the grid average.

About us

EDP Renewables North America LLC (EDPR NA), its affiliates, and its subsidiaries develop, construct, own, and operate wind farms and solar parks throughout North America. Headquartered in Houston, Texas, with 61 wind farms, 29 solar parks, four energy storage sites, and eight regional offices across North America, EDPR NA has developed more than 12,900 megawatts (MW) and operates more than 12,300 MW of onshore utility-scale renewable energy projects. With more than 1,000 employees, EDPR NA's highly qualified team has a proven capacity to execute projects across the continent.

For more information, visit www.edprnorthamerica.com

Twin Groves Wind Farm Operations & Maintenance Office

13682 N 2900 East Road
Ellsworth, IL 61737

713.208.8114
Jeffrey.Jacobs@edp.com